

The Rockwell 2000 Series Hardness Testers provide an industry-leading Gauge Repeatability and Reproducibility (GR&R) with accurate and repeatable test results using an electronic force monitoring apparatus and a precision depth measurement system. Featuring a durable frame, intuitive user panel, and a simple one-button operation, the Rockwell 2000 exceeds a wide variety of testing requirements. The Rockwell 2000 is available in Regular, Superficial, and Twin Scale models, as well as in two different sizes to suit numerous applications.





Technical Specifications

Model Number	2000R	2000S	2000T
Preliminary Load Kg (N)	10 (98.07)	3 (29.42)	3, 10 (29.42, 98.07)
Total Test Force Kg (N)	60, 100, 150 (588.4, 980.7, 1471)	15, 30, 45 (147.1, 294.2, 441.3)	15, 30, 45, 60, 100, 150 (147.1, 294.2, 441.3, 588.4, 980.7, 1471)
Test Scales	A, B, C, D, E, F, G, H, K, L, M, P, R, S, V	15N, 30N, 45N, 15T, 30T, 45T, 15W, 30W, 45W, 15X, 30X, 45X, 15Y, 30Y, 45Y	A, B, C, D, E, F, G, H, K, L, M, P, R, S, V 15N, 30N, 45N, 15T, 30T, 45T, 15W, 30W, 45W, 15X, 30X, 45X, 15Y, 30Y, 45Y
Horizontal Capacity	8.5 in (216 mm)		
Vertical Capacity	2002: 10 in (254 mm) 2003: 14 in (356 mm)		
Test Load Control	Closed-Loop Electronic Load Cell		
Specimen Illumination	12V 30W Halogen		
Data Output	RS-232		
Data Memory	999 tests per hardness scale		
Standards Compliant	ASTM E18, ASTM B254, ISO 6508, JIS Z2245		
Conversions	ASTM E140 or DIN-50150		
Statistics	Minimum, Maximum, Standard Deviation, Range, Mean, Number of Tests, Number of Good/Low/High Tests		
Resolution	.1 or .01 HR (adjustable)		
Power Supply	100, 120, 220 or 240 VAC +/-10%, 47 to 63 Hz single phase		
Test Cycle Type	Motorized (Auto load, test, and return)		
Languages	English and German		

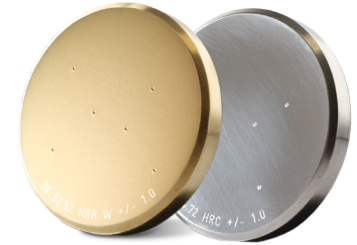

Test Blocks and Indenters

Wilson® Hardness offers NVLAP 17025 accredited Rockwell test blocks, diamond indenters, and ball penetrators



Accessories

- Vari Rest specimen support
- Clamping nosepiece for part pre-clip
- Anvils for internal and external ring/tube testing
- T-Slot table for clamping large test specimens
- Audible Alarm for part acceptance/rejection
- Data collection software for exporting to Microsoft® Excel®

Dimensions

Model Sizes	A		B		C		D		E		System Weight	
	mm	in	mm	in	mm	in	mm	in	mm	in	kg	lb
2002	1232 (48.5)	254 (10.0)	343 (13.5)	590 (23.2)	787 (31.0)	107 (236)						
2003	1334 (52.2)	356 (14.0)	343 (13.5)	590 (23.2)	990 (39.0)	113 (250)						

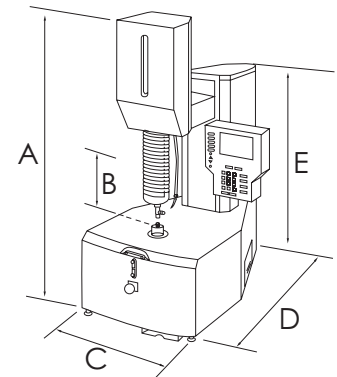

We are Local to You



Wilson Hardness
Americas • sales@wilson-hardness.com
Europe • europe.sales@wilson-hardness.com
Asia • asia.sales@wilson-hardness.com
www.wilson-hardness.com